



## TN725D - TN755D

### Tracked Feller Buncher / Tracked Harvester



#### STANDARD EQUIPMENT:

##### Engine and its related items:

- Cummins L9 Series Engine - 350HP
- Stage 5 - Single Modular DOC/DPF/SCR
- After-cooled, turbocharged, direct injection
- Air cleaner, double element
- Fuel pre filter, 10 micron
- Espar Heater

#### COOLING SYSTEM:

- 42" Hydraulic Fan, Variable Speed
- Auto Reverse

#### ELECTRICAL SYSTEM:

- Alternator (100 Amp / 24V)
- Batteries - 2 12V @ 1,000 CCA
- Work Lights - LED

#### FILTRATION SYSTEM:

- Charge Filter - Non By-Pass 6 micron
- Return Filter w/By-Pass 10 micron
- Case Drain Filter w/By-Pass 10 micron

#### GUARDS AND COVERS:

- Hydraulic Rear Gull Wing Canopy
- Side Access Service Doors
- Adjustable Side Platforms/Walkways
- Corner Post/Front Guard

#### HYDRAULIC CONTROLS:

- Rexroth Hydraulics
- IQAN MD4 Control
- Implement Pump - 145cc Variable Disp.
- Implement Pump - 175cc Variable Disp. (performance package)
- Swing Pump - Dedicated 90cc Hydrostatic Closed Loop
- Track Drive - Dual, 90cc, Hydrostatic
- Saw Pump - 60cc, piston
- Charge Pump -50cc gear pump
- Electric Hydraulic Fill Pump
- Hydraulic Tank Vacuum System
- Charge Relief Heater (hydraulic oil)

#### OPERATOR ENVIRONMENT:

- TimberPro Forestry Cab
- ROPS/FOPS/OPS Certified
- Three Emergency Escape Routes
- Digital Climate Control
- Heater, 38,000 BTU
- A/C, 35,000 BTU
- Fresh Air Filtered & Pressurized Cabin
- AM/FM/WB- Bluetooth/Handsfree Radio
- Deluxe Seat - Air Ride, Heat and Lumbar
- 4 Point Harness Seat Belt
- Led Lights
- Rearview Camera System
- IQAN MD4 Control with 10" Touch Screen
- Engine Management
- Troubleshooting Diagnostics
- Over & Under Temperature Protection

## Non-Leveling

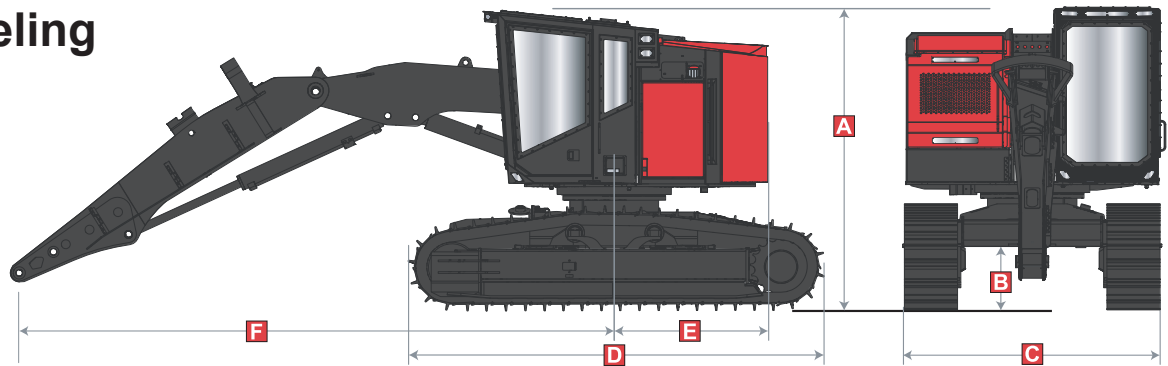

MODEL	TN725D	TN735D	TN745D	TN755D
<b>Operating Weight</b>	55,810 lb 23,315 kg	58,810 lb 26,676 kg	61,200 lb 27,560 kg	65,200 lb 29,574
<b>A</b>	11' 1"	11' 6"	11' 6"	11' 9"
<b>B</b>	27"	32"	32"	32"
<b>C</b>	9' 6" narrow 10' 4" std 11' 2" wide	9' 6" narrow 10' 4" std 11' 2" wide	10' 4" std 11' 2" wide	11' 2"
<b>D</b>	15' 4"	15' 4"	16' 5"	16' 5"
<b>E</b>	5' 9"	5' 9"	5' 9"	5' 9"
<b>F</b>	23' 9"	23' 9"	23' 9"	23' 9"
<b>HP</b>	350	350	350	350
<b>Fuel Capacity</b>	380 L	380 L	380 L	380 L
<b>Swing Torque</b>	57,800 ft/lb	57,800 ft/lb	57,800 ft/lb	64,608 ft/lb
<b>Tractive Effort</b>	68,629 lbs	80,066 lb	80,066 lb	108,745 lb
<b>REACH</b>				
<b>Buncher</b>	23' 9"	23' 9"	23' 9"	23' 9"
<b>Forwarder</b>	30'	30'	30'	30'
<b>Harvester</b>	30'	30'	30'	30'
<b>FB Main w/squirt</b>	29' 6"	29' 6"	29' 6"	29' 6"
<b>LIFTING CAPACITIES @ FULL REACH</b>				
<b>Buncher</b>	9,220 lbs	9,220 lbs	9,220 lbs	9,220 lbs
<b>Forwarder</b>	6,300 lbs	6,300 lbs	6,300 lbs	6,300 lbs
<b>Harvester</b>	7,700 lbs	7,700 lbs	7,700 lbs	7,700 lbs
<b>FB Main w/squirt</b>	7,300 lbs	7,300 lbs	7,300 lbs	7,300 lbs
<b>UNDERCARRIAGE</b>				
<b>Track Type</b>	D6	D7, D7G HD	D7, D7G HD	D7G HD
<b>No of Links</b>	45	45	48	48