

TB630D Wheeled Harvester



STANDARD EQUIPMENT:

Engine and its related items:

- Cummins L9 Series Engine - 350HP
- Stage 5 - Single Modular DOC/DPF/SCR
- After-cooled, turbocharged, direct injection
- Air cleaner, double element
- Fuel pre filter, 10 micron
- Espar Heater

COOLING SYSTEM:

- 42" Hydraulic Fan, Variable Speed
- Auto Reverse

ELECTRICAL SYSTEM:

- Alternator (100 Amp / 24V)
- Batteries - 2 12V @ 1,000 CCA
- Work Lights - LED

FILTRATION SYSTEM:

- Charge Filter - Non By-Pass 6 micron
- Return Filter w/By-Pass 10 micron
- Case Drain Filter w/By-Pass 10 micron

GUARDS AND COVERS:

- Hydraulic Rear Gull Wing Canopy
- Side Access Service Doors
- Adjustable Side Platforms/Walkways (option)

UPPER TURNTABLE SWING:

- Swing Brake, Wet Multi Disc
- Continuous Rotation

HYDRAULIC CONTROLS:

- IQAN MD4 Control
- Implement Pump - 145cc Variable Disp.
- Implement Pump - 175cc Variable Disp. (performance package)
- Wheel Drive Pump - 125cc
- Charge Pump -50cc gear pump
- Electric Hydraulic Fill Pump
- Hydraulic Tank Vacuum System
- Charge Relief Heater (hydraulic oil)

OPERATOR ENVIRONMENT:

- TimberPro Forestry Cab
- ROPS/FOPS/OPS Certified
- Three Emergency Escape Routes
- Digital Climate Control
- Heater, 38,000 BTU
- A/C, 35,000 BTU
- Fresh Air Filtered & Pressurized Cabin
- AM/FM/WB- Bluetooth/Handsfree Radio
- Deluxe Seat - Air Ride, Heat and Lumbar
- 4 Point Harness Seat Belt
- Led Lights
- Reaview Camera System
- IQAN MD4 Control with 10" Touch Screen
- Engine Management
- Troubleshooting Diagnostics
- Over & Under Temperature Protection

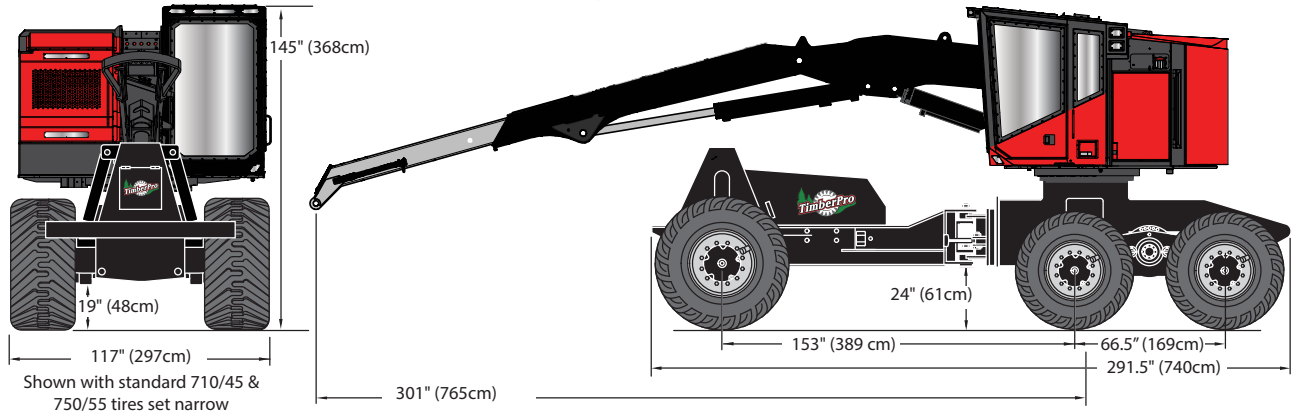

| MODEL | TB630D |
|--------------------------------------|--------------|
| Operating Weight | 48,280 lbs |
| Gross Capacity | 20 ton |
| SPECS | |
| HP | 350 |
| Fuel Capacity | 380 L |
| Swing Torque | 57,800 ft/lb |
| REACH | |
| Fwd Main Boom and Arm | 25' 6" |
| Fwd Main Boom and 6' Squirt | 31' 6" |
| Feller Buncher Boom and Arm | 23' 9" |
| Feller Buncher Boom & 6' Squirt | 31' 6" |
| LIFTING CAPACITIES @ FULL REAACH | |
| Fwd Main Boom and Arm | |
| Fwd Main Boom and 6' Squirt | 6,320 lbs |
| Feller Buncher Boom and Arm | 10,800 lbs |
| Feller Buncher Boom & 6' Squirt | 7,300 lbs |
| TIRES | |
| Nokian 710/45 26.5 FK F2 ELS (front) | STD |
| Nokian 750/55 26.5 F2 FK ELS (rear) | STD |
| TRS Option | Opt |
| OPTIONS | |
| Fwd Main Boom and Arm | STD |
| Fwd Main Boom and 6' Squirt | Opt |
| Feller Buncher Boom and Arm | Opt |
| Feller Buncher Boom & 6' Squirt | Opt |
| Leveling Frame | Opt |
| Blade | Opt |
| Quick Change Boom Adapter | Opt |