

HX07

Haulage truck



Safety



Reliability



Productivity



Capacities

Standard payload	6 600 kg (14,520 lbs.)
Standard box	3.3 m ³ (4.29 yd ³)

Engine

Engine	72 kW (96 HP)
--------	---------------

HX07

Weights

Operating	8 545 kg (19,000 lbs.)
Total loaded weight	15 145 kg (33,320 lbs.)
Axle weight without load	
Front axle	6 045 kg (13,300 lbs.)
Rear axle	2 591 kg (5,700 lbs.)
Axle weight with load	
Front axle	6 873 kg (15,120 lbs.)
Rear axle	8 273 kg (18,200 lbs.)

Driving speeds loaded

Grade	0%	10%	15%
1st gear	3.4 kph (2.1 mph)	3.4 kph (2.1 mph)	3.4 kph (2.1 mph)
2nd gear	7.7 kph (4.8 mph)	7.5 kph (4.7 mph)	7.3 kph (4.5 mph)
3rd gear	23 kph (14.3 mph)	5.62 kph (3.5 mph)	

Box motion times (+/-1s)

Raising time	8.0 s
Lowering time	6.0 s

Articulation motion times (+/-1 s)

Turning time: right	2.5 s
Turning time: left	2.4 s

Electrical equipment

Alternator	24V/100A
Batteries	2x24V
Starter	24V heavy duty
Driving and working lights	2 front/2 rear

Structural

Front and rear frames	Welded steel box construction
Material	ASTM A572 GR50

Engine

Engine	Deutz BF4L914
Certification	EPA Tier 2
Displacement	4.3 L
Output	72 kW (96 HP) @ 1600 rpm
Maximum torque	355 N-m (264 ft.-lbs.) @ 1600 rpm
Number of cylinders	4
Cooling type	Air cooled
Induction type	Turbo charged
Governor	Mechanical

Powertrain

General	
Air filtration	Donaldson (dry type)
Exhaust system	Diesel oxidation catalyzer
Fuel tank capacity	117 L (31 US gal)
Converter	Integral
Transmission	Dana HR20000 series
Shifting	Powershift c/w modulation
Speeds	3 forward/3 reverse
Axles	
Front and rear	Dana 113 series
Differentials, front	Open
Differentials, rear	Open
Breaks	Hydraulic apply, inboard disk
Oscillation angle	+/- 10 deg (frame)
Tires	Radial lugged
Size	9.00 x 20

Hydraulics

System design - Variable displacement piston pump with load sensing closed center circuit design for optimal efficiency. Electric transfer pump for tank filling.

Dump control	Hydraulic
Steering control	Steering wheel
Box hoist cylinder	Two, double acting, single stage
Steer cylinder	Two, double acting, single stage
Hydraulic tank volume	108 L (28.5 gal)

Brake system - Service brakes are enclosed hydraulic apply, spring release disk brakes, located inboard. The emergency and park brakes are spring apply. Brakes will apply upon loss of hydraulic pressure or electrical power.

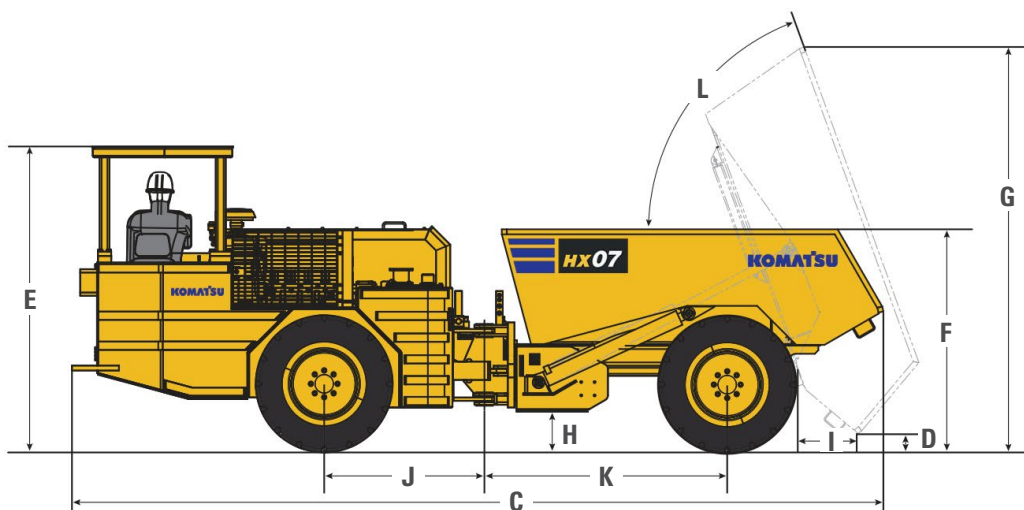
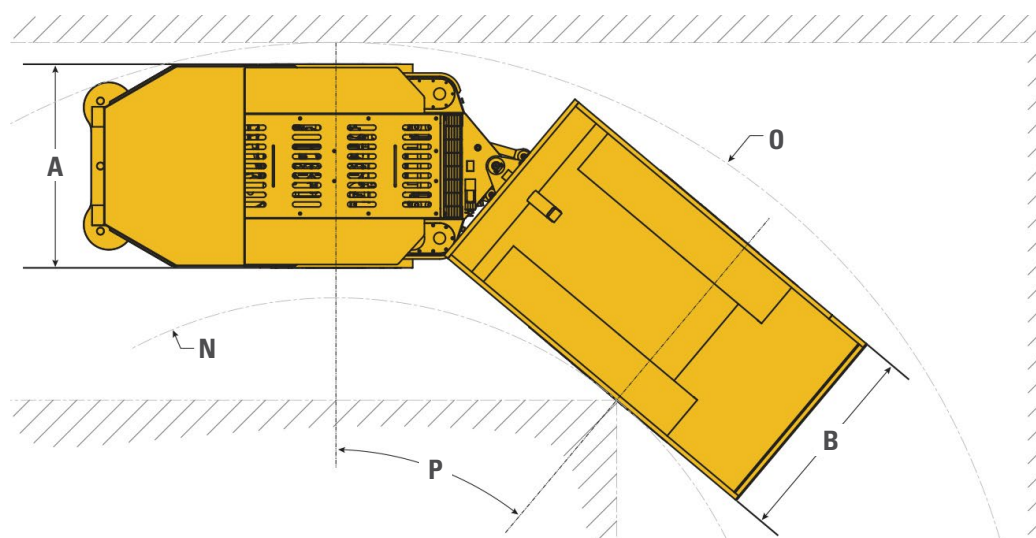

Overall dimensions

A	Width without dump box	1 548 mm (61 in)
B	Maximum width	1 549 mm (61 in)
C	Tramming length	6 217 mm (245 in)
D	Height - dump clearance	109 mm (4 in)
E	Height at protective canopy*	2 084 mm (82 in)
F	Height at dump box*	1 781 mm (70 in)
G	Dump height*	3 108 mm (122 in)
H	Ground clearance*	234 mm (9 in)
I	Length - dump clearance	690 mm (27 in)
J	Length - front axle to center hinge	1 219 mm (48 in)
K	Length - rear axle to center hinge	1 925 mm (76 in)
L	Dump box angle	70 deg

Turning radius

N	Right inner	3,186 mm (125 in)
O	Right outer	5,157 mm (203 in)
P	Turning angle	42 deg

*Vehicle height and ground clearance will vary with tire manufacturer, tire pressure and load. With the vehicle loaded, expect tires to compress up to 44 mm (1.75 in).

Features

Centralized autolubrication system	<input type="radio"/>
Fire extinguisher	<input type="radio"/>
Fire suppression system (manual, automatic)	<input type="radio"/>
Spare rim/wheel	<input type="radio"/>

Further equipment on request

- standard equipment
- optional equipment

Product designs, specifications and/or data in this document are provided for informational purposes only and are not warranties of any kind. Product designs and/or specifications may be changed at any time without notice. The only warranties that apply to sales of products and services are Komatsu's standard written warranties, which will be furnished upon request.

Komatsu and other trademarks and service marks used herein are the property of Komatsu Ltd., Komatsu America Corp., Komatsu Mining Corp., or one of their affiliates, or the respective owners or licensees.

KOMATSU

mining.komatsu

