

TECHNICAL DATA

COMBINATION ROLLER

BW 90 AC-5

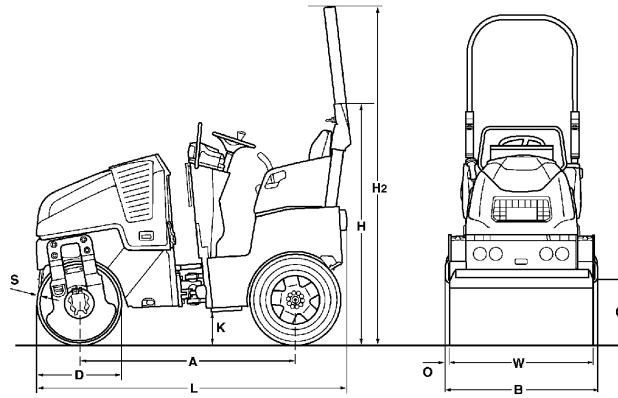



Dimensions in mm

	A	B	C	D	H	H2	K	L	O	S	W
BW 90 AC-5	1483	956	433	580	1627	2304	255	2194	28	12	900

Shipping dimensions in m3

BW 90 AC-5

without ROPS

3,413

with ROPS

4,833

Machine type	Compaction output (t/h) at different asphalt layer thicknesses		
	2-4 cm	6-8 cm	10-14 cm
BW 90 AC-5	10-35	30-45	40-70

Technical Data

BOMAG BW 90 AC-5

Weights

Operating weight CECE	kg	1.600
Axle load, drum / wheels CECE	kg	755/845
Wheel load CECE	kg	211
Static linear load, front CECE	kg/cm	8,4
Grossweight	kg	1.900

Dimensions

Working width	mm	900
Track radius, inner	mm	2.030

Driving Characteristics

Speed	km/h	0- 10,0
Working speed with vibration	km/h	0- 10,0
Max. gradeability without/with vibr.	%	40/30

Drive

Engine manufacturer		Kubota
Type		D 902
Emission stage		Stage V / TIER4f
Cooling		water
Number of cylinders		3
Performance ISO 14396	kW	15,1
Performance SAE J 1995	hp	20,2
Speed	min-1	3.000
Speed adjustment 1	min-1	2.100
Speed adjustment 2	min-1	3.000
Electric equipment	V	12
Driven drum		front
Driven wheels		4

Drums and Tyres

Tyre size		190/60-15
-----------------	--	-----------

Brakes

Service brake		hydrost.
Parking brake		hydromec.

Steering

Steering system		oscil.artic.
Steering method		hydrost.
Steering / oscillating angle +/-	grad	33/8
Crab walk	mm	0- 50

Exciter system

Vibrating drum		front
Drive system		hydrost.
Frequency	Hz	42/63
Amplitude	mm	0,50
Centrifugal force	kN	8/17

Sprinkler System

Type of sprinkling		pressure
--------------------------	--	----------

Capacities

Fuel	l	30,0
Water	l	100,0
Emulsion	l	11,0

Technical modifications reserved. Machines may be shown with options.

Standard Equipment

- Four smooth rear rubber wheels
- Hydrostatic travel and vibration drive
- 2 scrapers per drum, spring loaded and tiltable
- Pressure sprinkler system with interval switch
- Multi function travel lever
- Multi-function display incl. operating hour meter
- Water level
- Emergency STOP
- Intelligent Vibration Control (IVC)
- Integrated storage compartment
- Adjustable operator's seat
- Seat contact switch
- Vandalism protection
- 12V socket
- Working lights front and rear
- Back-up alarm
- Lockable engine hood made of composite material
- Lashing eyes, galvanized
- Single point lifting device

Optional Equipment

- ROPS with safety belt
- * Foldable ROPS incl. seat belt
- Double travel lever
- Seat heating
- ECONOMIZER with asphalt temperature display
- Temperature display
- BOMAG TELEMATIC
- Electronic fuel gauge
- Theft protection
- Indicator and hazard lights
- Rotary beacon
- Optional lighting on ROPS
- Battery disconnect switch
- Environmentally compliant hydraulic oil
- Special painting
- Edge cutter
- Port for hydraulik breaker
- Backup warning buzzer with broadband technology
- Brake release device
- ECOSTOP
- Outside mirrors
- Tablet holder set

* Standard delivery with CE conformity
(valid within European Union)

